

Geometry Midterm Review

Name: _____

1. Show your work.

a. Calculate the value of x .

25

b. Calculate the value of y .

78

c. Calculate the value of z .

24

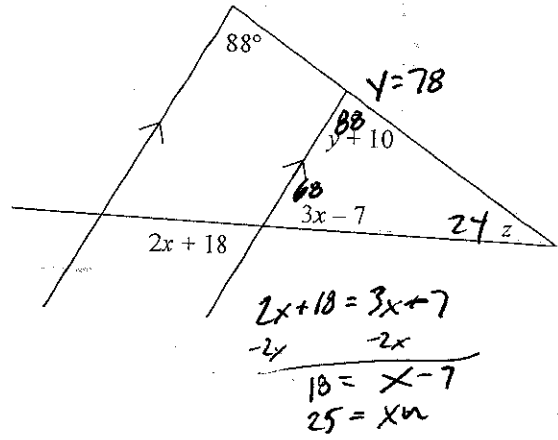

2. Multiple Choice: Which of the following lengths cannot form a triangle?

I. 3, 4, 6

II. 5, 6, 13

III. 6, 7, 13

A. I only

B. II only

C. III only

D. II and III

E. I, II, III

3. Multiple Choice: The length of the line segment joining the points $(-2, 3)$ and $(4, -2)$ is:

A. $\sqrt{3}$

B. $\sqrt{11}$

C. $\sqrt{29}$

D. $\sqrt{61}$

E. none of these

4. Multiple Choice: A right triangle has a hypotenuse of 5 and one leg with length of 2. What is the length of the other leg.

A. 3

B. $\sqrt{21}$

C. $\sqrt{29}$

D. 7

E. none of these

5. Find the area of this figure. Show your dissections and any sub problems you use.

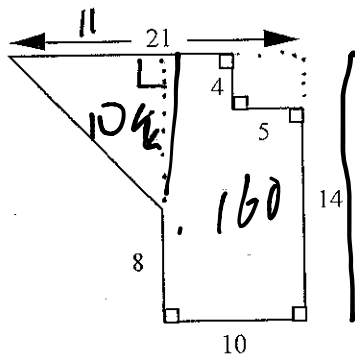

Area

$$(10 \times 11) - (4 \times 5) + \left(\frac{1}{2} \cdot 10 \cdot 11\right)$$

$$110 - 20 + 55 = 145$$

160

145

215

6. Find the area of each of these figures.

a.

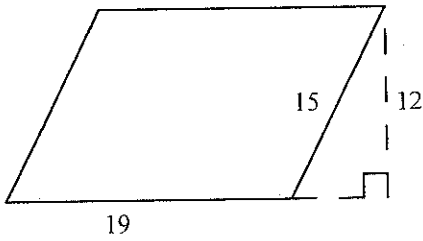

$$19 \times 12 = 228 \text{ un}^2$$

b.

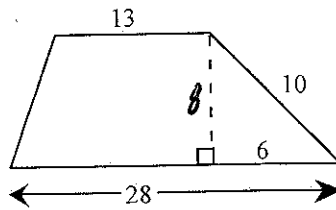

$$\frac{1}{2} (13 + 28) \cdot 8 = 164 \text{ un}^2$$

c.

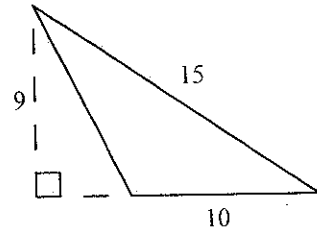

$$\frac{1}{2} 9 \cdot 10 = 45 \text{ un}^2$$

7. Draw the triangle that results when $\triangle ABC$ is rotated 180° counterclockwise about the origin. You may use tracing paper.

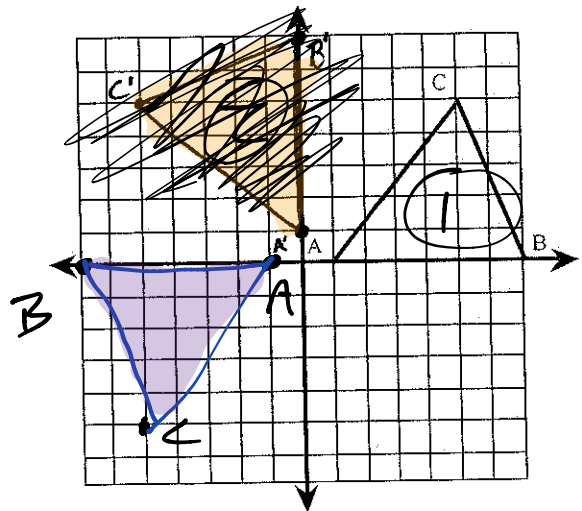

8. Four lines intersect as shown in the figure at right. If $z = 40^\circ$ what is the value of $x + y$?

280

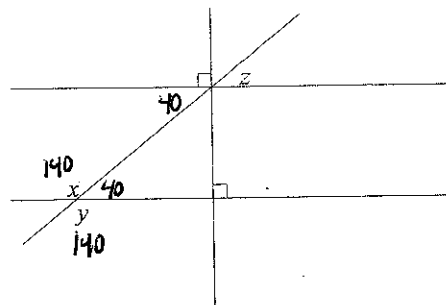

9. For each pair of triangles below, decide if the triangles are similar. If so, make a flowchart and find the value of x . If not, or there is not enough information, describe why not or what information is missing.

a.

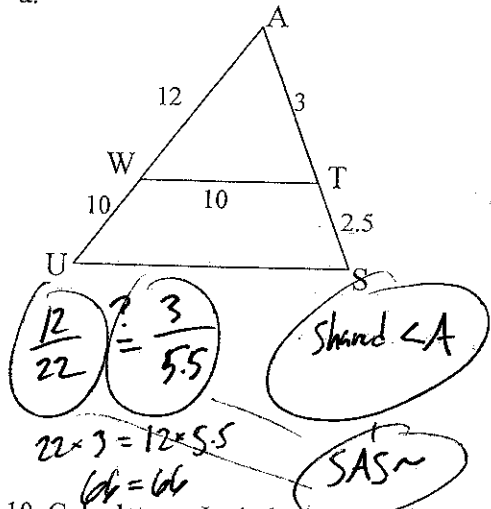

b.

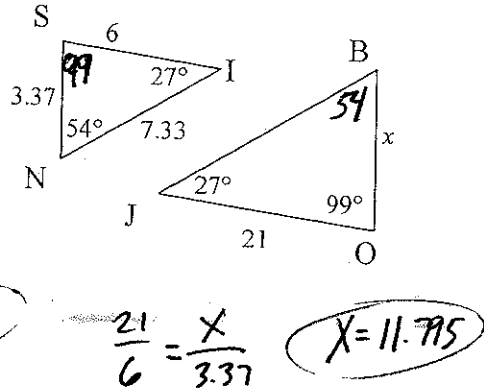

10. Calculate x . Include the steps in your solution and the definitions and/or conjectures that you use.

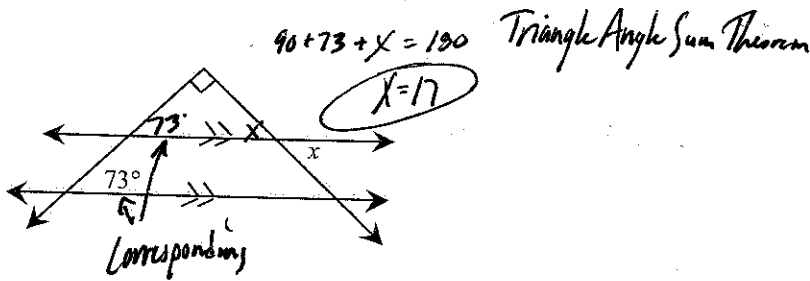

11. Calculate the area and perimeter of the trapezoid below. Show your work.

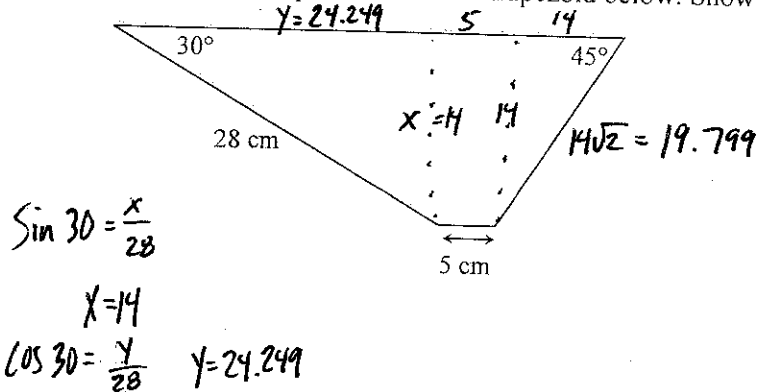

Perimeter = 96.048 cm

$\text{Area} = \left(\frac{1}{2} \cdot 14 \cdot 24.249\right) + (5 \cdot 14) + \left(\frac{1}{2} \cdot 14 \cdot 14\right)$
 $= 169.743 + 70 + 98$
 $= 337.743 \text{ cm}^2$

12. Find the measure of angle a in the diagram below.

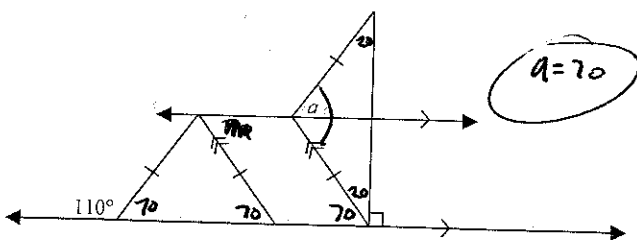

13. Tyree planned to build a ramp from his window to the sidewalk so he could skateboard right out his window on his way to school. His window is 5 feet off the ground and the sidewalk is 20 feet from his house.

- a. Draw a diagram to represent this situation.

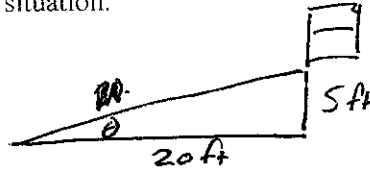

- b. How long will Tyree's ramp need to be to make it from his window to the sidewalk?

20.62 feet, solved with Pythagorean Theorem

- c. He knows that if the angle the ramp makes with the ground is more than 20° he will gain too much speed and lose control when he hits the sidewalk. Find the angle his ramp will make with the ground to determine whether or not his ramp plan will be safe.

$$\tan \theta = \frac{5}{20}$$

$\theta \approx 14^\circ$ safe! and awesome.

14. Examine the diagram below. Then use the information provided in the diagram to find the measures of angles a through g . For each angle, name the angle relationship that helped justify your conclusion.

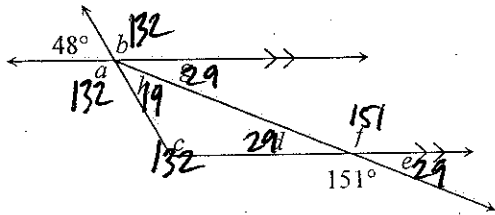

15. Plot the points $A(-3, -2)$ and $B(2, 4)$, and connect them to form \overline{AB} . What is the length of \overline{AB} ? How do you know? Show your work and justify your response.

$$5^2 + 6^2 = \sqrt{61}$$

$$c = \sqrt{61}$$

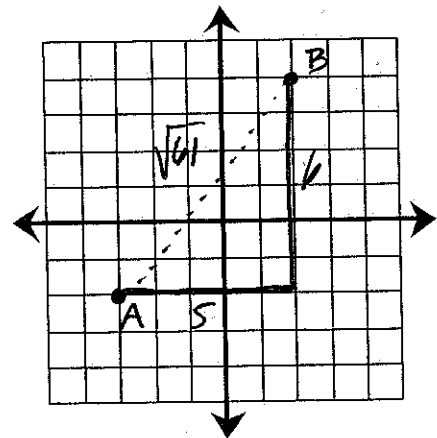

16. Calculate the value of x for each triangle below. Show all work. Note: pictures are not drawn to scale.

a.

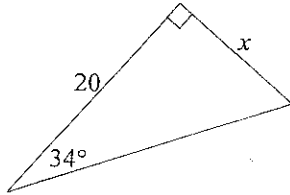

$$\tan 34 = \frac{x}{20}$$

$$x = 13.5$$

b.

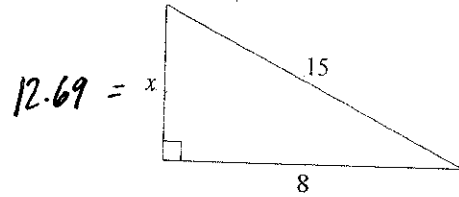

$$12.69 = x$$

c.

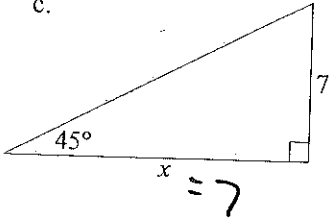

$$x = 7$$

d.

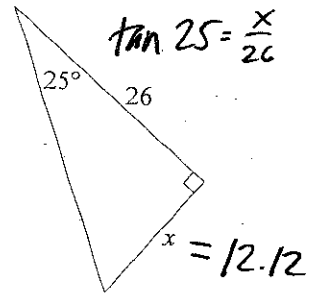

$$\tan 25 = \frac{x}{26}$$

$$x = 12.12$$

17. Jerome needs to place a fence around his flowerbed and his yard so that his dog can only run in the grassy area. Note: the yard is shaded in the figure at right.

a. How much area will Jerome's dog have to run in? Show all work and subproblems.

$$(18 \times 8) + \left(\frac{1}{2} \times 9 \times 12\right) - \left(\frac{1}{2} \times (10 + 5) \times (6)\right)$$

$$144 + 54 - 45$$

$$153$$

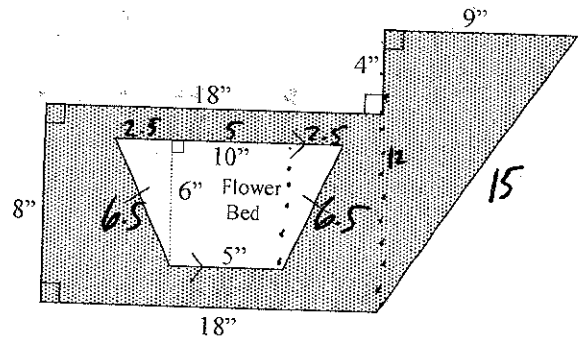

b. How much fencing will Jerome need to buy to keep his dog in the yard but out of the flowerbed?

$$(15 + 9 + 4 + 18 + 8 + 18) + (10 + 6.5 + 5 + 6.5)$$

$$72 + 28$$

$$100$$

18. When Feng's brother bragged that he had climbed 120 feet to the top of the oak tree down at the park, Feng decided to try to prove him wrong. She went to the park and stood 20 feet from the base of the tree. She then used her clinometer to measure the angle of elevation to the top of the tree and got an angle measure of 72° . Her eye height was 5 feet. Assuming her brother did climb to the top of the tree, did he climb 120 feet up the tree? Justify your answer.

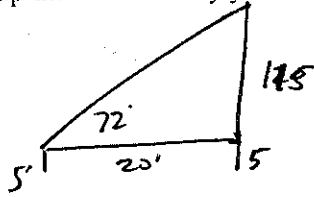

$$\tan 72^\circ = \frac{115}{20}$$

$$3.078 \neq 5.75$$

NO He didn't

19. What are the possible lengths for side \overline{ML} in the triangle at right? Show how you know.

$$14 > \overline{ML} > 6$$

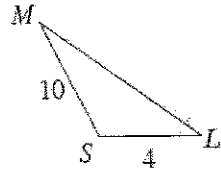

20. Dilate the shape below using a zoom factor of 3 from the origin.

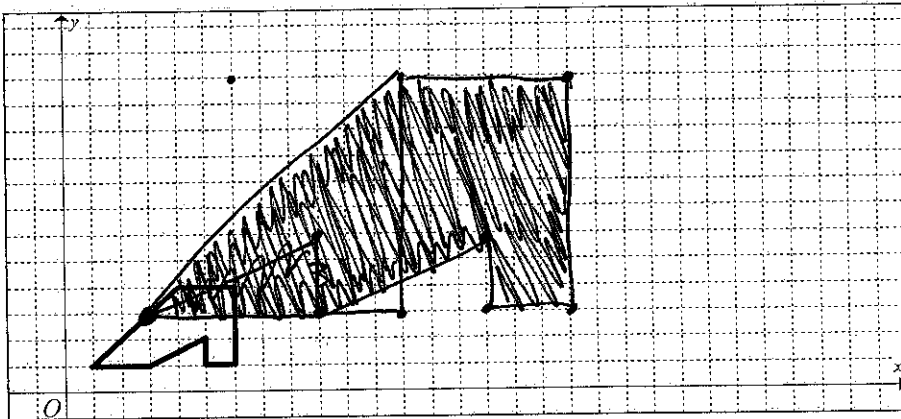

21. True or False? If false, state why.

T If a shape is magnified by a factor of k , the ratio of perimeters between the new figure and the original figure is k .

F If two shapes are congruent, then their zoom factor is zero

T All equilateral triangles are similar.

F All rectangles are similar.

F If a shape is magnified by a factor of k , the ratio of areas between the new figure and the original figure is k .